

Pride LX

Owner's Manual

ATTENTION:
Please read the content
of your owner's manual
before operating your
power chair.



Pride
Mobility Products Ltd.

*Unit 106, Heyford Park Camp Road
Upper Heyford, Oxfordshire OX25 5HA*

www.pridemobility.com

SAFETY GUIDELINES

The symbols below are used throughout this owner's manual and on the power chair to identify warnings and important information. It is very important for you to read them and understand them completely.



WARNING! Failure to follow designated procedures can cause either personal injury, component damage or malfunction.



MANDATORY! These actions should be performed as specified. Failure to perform mandatory actions can cause injury to personnel and/or damage to equipment.



PROHIBITED! These actions are prohibited. These actions should not be performed at any time or in any circumstances. Performing a prohibited action can cause injury to personnel and/or damage to equipment.



C O N T E N T S

I. INTRODUCTION	4
II. SAFETY	5
III. YOUR POWER CHAIR.....	13
IV. ASSEMBLY/DISASSEMBLY	17
V. COMFORT ADJUSTMENTS.....	21
VI. BATTERIES AND CHARGING	24
VII. OPERATION.....	28
VIII. CARE AND MAINTENANCE	35
IX. WARRANTY	40

This owner’s manual is compiled from the latest specifications and product information available at the time of publication. We reserve the right to make changes as they become necessary. Any changes to our products may cause slight variations between the illustrations and explanations in this manual and the product you have purchased.

I . I N T R O D U C T I O N

SAFETY

WELCOME to Pride Mobility Products Corporation (Pride). The power chair you have purchased combines state-of-the-art components with **safety**, comfort and styling in mind. We are confident that these design features will provide you with the conveniences you expect during your daily activities. Once you understand how to **safely** operate and care for your power chair, it should give you years of trouble free operation and service.

Read and follow all instructions, warnings and notes in this manual before attempting to operate your power chair for the first time. In addition, your **safety** depends upon you, as well as your dealer, carer or healthcare professional in using good judgement.

If there is any information in this manual which you do not understand or if you require additional assistance for setup or operation, please contact your authorised Pride Dealer. **Failure to follow the instructions in this manual and those located on your power chair can lead to personal injury and/or damage to the power chair, including voiding the warranty.**

PURCHASER'S AGREEMENT

By accepting delivery of this product, you promise that you will not change, alter or modify this product or remove or render inoperable or unsafe any guards, shields or other safety features of this product; fail, refuse or neglect to install any retrofit kits from time to time provided by Pride to enhance or preserve the safe use of this product.

INFORMATION EXCHANGE

We want to hear your questions, comments and suggestions about this manual. We would also like to hear about the safety and reliability of your new power chair and about the service you received from your authorised Pride Dealer.

Please notify us of any change of address, so we can keep you apprised of important information about safety, new products and new options that can increase your ability to use and enjoy your power chair. Please feel free to contact us at the address below:

Pride Mobility Products Ltd.
Unit 106, Heyford Park Camp Road
Upper Heyford, Oxfordshire OX25 5HA

NOTE: If you ever lose or misplace your product registration card or your copy of this manual, contact us and we will be glad to send you a new one immediately.

My authorised Pride Dealer:

Name: _____

Address: _____

Phone Number: _____

Purchase Date: _____

II. SAFETY

SAFETY



MANDATORY! Do not operate your new power chair for the first time without completely reading and understanding this owner's manual.

Your power chair is a state-of-the-art life-enhancement device designed to increase mobility. Pride provides an extensive variety of products to best fit the individual needs of the power chair user. Please be aware that the final selection and purchasing decision regarding the type of power chair to be used is the responsibility of the power chair user, who is capable of making such a decision and his/her healthcare professional (i.e., medical doctor, physical therapist, etc.).

The contents of this manual are based on the expectation that a mobility device expert has properly fitted the power chair to the user and has assisted the prescribing healthcare professional and/or the authorised Pride Dealer in the instruction process for the use of the product.

There are certain situations, including some medical conditions, where the power chair user will need to practice operating the power chair in the presence of a trained attendant. A trained attendant can be defined as a family member or care professional specially trained in assisting a power chair user in various daily living activities.

As you begin using your power chair during daily activities, you will probably encounter situations in which you will need some practice. Simply take your time and you will soon be in full and confident control as you manoeuvre through doorways, on and off of lifts, up and down ramps and over moderate terrain.

Below are some precautions, tips and other safety considerations that will help you become accustomed to operating the power chair safely.

Modifications

Pride has designed and engineered your power chair to provide maximum mobility and utility. A wide range of accessories is available from your authorised Pride Dealer to further customise your power chair to better suit your needs and/or preferences. However, under no circumstances should you modify, add, remove or disable any feature, part or function of your power chair.



WARNING! Do not modify your power chair in any way not authorised by Pride. Unauthorised modifications may result in personal injury and/or damage to your power chair.

Pre-Ride Safety Check

Get to know the feel of your power chair and its capabilities. Pride recommends that you perform a safety check before each use to make sure your power chair operates smoothly and safely. See VIII. "Care and Maintenance."

Perform the following inspections prior to using your power chair:

- Check for proper tyre inflation. Maintain **2.4 bar (35 psi)** in each tyre if equipped with pneumatic tyres.
- Check all electrical connections. Make sure they are tight and not corroded.
- Check all controller connections to the electronics tray. Make sure they are secured properly.
- Check the brakes. See VIII. "Care and Maintenance."
- Check battery charge. See VI. "Batteries and Charging."

NOTE: *If you discover a problem, contact your authorised Pride Dealer for assistance.*

II. SAFETY

Weight Limitations

Your power chair is rated for a maximum weight capacity. Please refer to the specifications table for this limit.



WARNING! Exceeding the weight capacity voids your warranty and may result in personal injury and/or damage to your power chair. Pride will not be held responsible for injuries and/or property damage resulting from failure to observe weight limitations.

WARNING! Do not carry passengers on your power chair. Carrying passengers on your power chair may result in personal injury and/or property damage.

Tyre Inflation

If your power chair is equipped with pneumatic tyres, you should check or have the air pressure checked at least once a week. Proper inflation pressures will prolong the life of your tyres and help ensure the smooth operation of your power chair.



WARNING! It is important that 2.4 bar (35 psi) tyre pressure be maintained in pneumatic tyres at all times. Do not underinflate or overinflate your tyres. Low pressure may result in loss of control and overinflated tyres may burst. Failure to maintain 2.4 bar (35 psi) tyre pressure in pneumatic tyres at all times may result in tyre and/or wheel failure, causing serious personal injury and/or damage to your power chair.

WARNING! Inflate your power chair drive tyres from a regulated air source with an available pressure gauge. Inflating your tyres from an unregulated air source could overinflate them, resulting in a burst tyre and/or personal injury.

WARNING! When changing a tyre, remove only the centre lug nut, then remove the tyre. If any further disassembly is required, deflate the tyre completely or it may explode, possibly resulting in personal injury.

Incline Information

More and more buildings have ramps with specified degrees of inclination, designed for easy and safe access. Some ramps may have turning switchbacks (180-degree turns) that require you to have good cornering skills on your power chair.

- Proceed with extreme caution as you approach the downgrade of a ramp or other incline.
- Take wide swings with your power chair's front wheels around any tight corners. If you do that, the power chair's rear wheels will follow a wide arc, not cut the corner short and not bump into or get hung up on any railing corners.
- When driving down a ramp, keep the power chair's speed adjustment set to the slowest speed setting to ensure a safely controlled descent. See VII. "Operation."
- Avoid sudden stops and starts.

When climbing an incline, try to keep your power chair moving. If you must stop, start up again slowly and then accelerate cautiously. When driving down an incline, set your power chair to the slowest setting and drive in the forward direction only. If your power chair starts to move down the incline faster than you anticipated or desired, allow it to come to a complete stop by releasing the joystick, then push the joystick forward slightly to ensure a safely controlled descent.



WARNING! When climbing an incline, do not zigzag or drive at an angle up the face of the incline. Drive your power chair straight up the incline. This greatly reduces the possibility of a tip or a fall. Always exercise extreme caution when negotiating an incline.

II. SAFETY

WARNING! You should not travel up or down a potentially hazardous incline (i.e., areas covered with snow, ice, cut grass or wet leaves).

WARNING! When on any sort of an incline or decline, never place the power chair in freewheel mode while seated on it or standing next to it. Doing so may result in personal injury and/or damage to your power chair.



WARNING! Never travel down an incline rearwards. This may result in personal injury.

WARNING! Your power chair may be equipped with a reclining seatback. This feature is intended for use on a flat, level surface. Do not negotiate inclines with the seat in a reclined position as this may result in the power chair tipping over and causing personal injury and/or product damage.

WARNING! Even though your power chair is capable of climbing slopes greater than those illustrated in figure 1, do not, under any circumstances, exceed the incline guidelines or any other specifications presented in this manual. Doing so could cause instability in your power chair, resulting in personal injury and/or damage to your power chair.

Pride recommends that the maximum slope of an incline you attempt to safely ascend or descend on your power chair does not exceed 8.7% (5°). See figure 1.



WARNING! Any attempt to climb or descend a slope steeper than 8.7% (5°) may put your power chair in an unstable position and cause it to tip, resulting in personal injury.

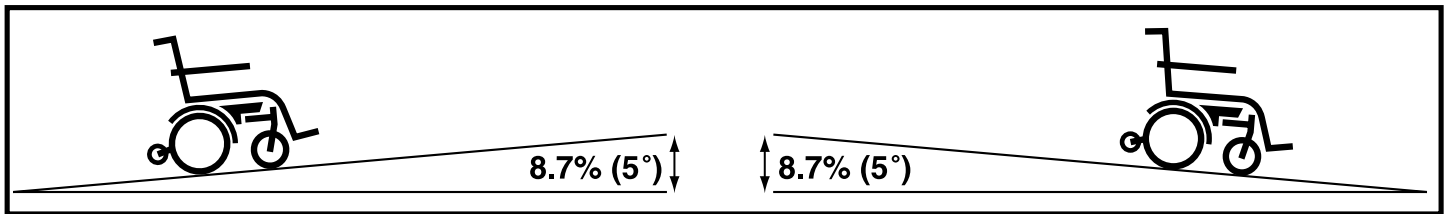

Figure 1. Maximum Safe Angle (Ascending and Descending)

Braking Information

Your power chair is equipped with two powerful brake systems:

1. Regenerative — uses electricity to rapidly slow the vehicle when the joystick returns to the centre/stop position.
2. Disc Park Brake — activates mechanically after regenerative braking slows the vehicle to near stop or when power is removed from the system for any reason.

Cornering Information

While your power chair is equipped with front castor wheels and rear anti-tip wheels, excessively high cornering speeds can still create the possibility of tipping. Factors which affect the possibility of tipping include, but are not limited to: cornering speed, steering angle (how sharply you are turning), uneven road surfaces, inclined road surfaces, riding from an area of low traction to an area of high traction (such as passing from a grassy area to a paved area – especially at high speed while turning) and abrupt directional changes. High cornering speeds are not recommended. If you feel that you may tip over in a corner, reduce your speed and steering angle (i.e., lessen the sharpness of the turn) to prevent your power chair from tipping.



WARNING! When cornering sharply, reduce your speed. This greatly reduces the possibility of a tip or fall. To avoid personal injury and/or property damage, always exercise common sense when cornering.

II. SAFETY

Outdoor Driving Surfaces

Your power chair is designed to provide optimum stability under normal driving conditions—dry, level surfaces composed of concrete, blacktop or tarmac. However, Pride recognises that there will be times when you will encounter other surface types. For this reason, your power chair is designed to perform admirably on packed soil, grass and gravel. Feel free to use your power chair safely on lawns and in park areas.

- Reduce your power chair's speed when driving on uneven terrain and/or soft surfaces.
- Avoid tall grass that can entangle the running gear.
- Avoid loosely packed gravel and sand.
- If you feel unsure about a driving surface, avoid that surface.

Freewheel Mode

Your power chair is equipped with a manual freewheel system to allow for manual manoeuvrability by a trained attendant. For more information about how to place your power chair into and out of freewheel mode, see III. "Your Power Chair."

WARNING! Do not use your power chair in freewheel mode without an attendant present. Personal injury may result.



WARNING! Do not attempt to personally place your power chair in freewheel mode while seated on it. Personal injury may result. Ask an attendant for assistance if necessary.

WARNING! Do not place your power chair in freewheel mode while on an incline. The chair could roll uncontrollably on its own, causing personal injury.

Stationary Obstacles (Steps, Kerbs, etc.)

Proceed with extreme caution when driving near raised surfaces, unprotected ledges and/or drop-offs (kerbs, porches, stairs, etc.). The correct method for approaching a kerb is illustrated in figure 2.

WARNING! Do not attempt to have your power chair climb or descend an obstacle that is higher than 5 cm (2 in.) unless you have the assistance of an attendant.



WARNING! If your power chair is equipped with a kerb climber, do not attempt to climb any kerb in excess of 5 cm (2 in.) in height. Do not approach kerbs at an angle; instead approach any kerb you intend to ascend or descend in the forward position.

WARNING! Do not attempt to have your power chair proceed rearward down any step, kerb or other obstacle. This may cause the power chair to tip and cause personal injury.

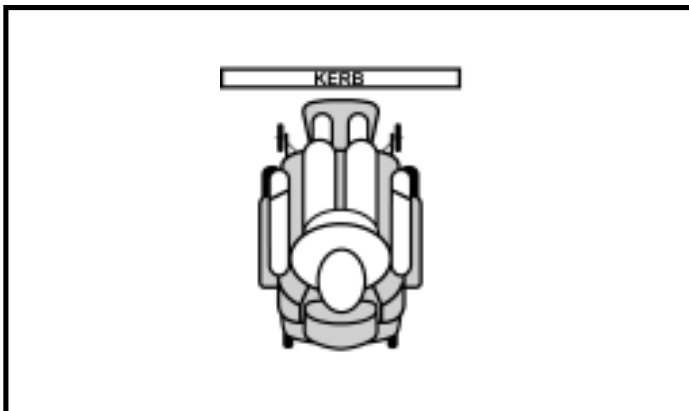

Figure 2. Correct Kerb Approach



Figure 3. Incorrect Kerb Approach

II. SAFETY

Public Streets and Roadways



WARNING! You should not operate your power chair on public streets and roadways. Be aware that it may be difficult for traffic to see you when you are seated on your power chair. Obey all local pedestrian traffic rules. Wait until your path is clear of traffic, and then proceed with extreme caution.

Inclement Weather Precautions

Exposure of your power chair to inclement weather conditions should be avoided whenever possible. If suddenly caught up in rain, snow, severe cold or heat while operating your power chair, proceed to shelter at the earliest opportunity. Thoroughly dry your power chair before storing, charging or operating your power chair.



WARNING! Operating in rain, snow, salt, mist/spray conditions and on icy/slippery surfaces can cause personal injury and/or damage to the power chair and electrical system. Maintain and store your power chair in a dry and clean condition.

Stairs and Escalators

Power chairs are not designed to travel up or down stairs or escalators. Always use a lift.



WARNING! Never use your power chair to negotiate steps or escalators. You may cause injury to yourself and to others and/or damage your power chair.

Doors

- Determine if the door opens toward or away from you.
- Drive your power chair gently and slowly forward to push the door open. Or drive your power chair gently and slowly rearward to pull the door open.

Lifts

Modern lifts have a door edge safety mechanism that, when pushed, reopens the lift door(s).

- If you are in the doorway of a lift when the door(s) begin to close, push on the rubber door edge or allow the rubber door edge to contact the power chair and the door will reopen.
- Use care that handbags, packages or power chair accessories do not become caught in lift doors.

Motor Vehicle Transport

Pride recommends that you do not remain seated in your power chair while traveling in a motor vehicle. The power chair should be stowed in the boot of a car or in the back of a truck or van with the batteries removed and properly secured.

WARNING! Although your power chair may be equipped with a positioning belt, this belt is not designed to provide proper restraint during motor vehicle transport. Anyone traveling in a motor vehicle should be properly secured in the motor vehicle seat with safety belts fastened securely.



WARNING! Do not sit on your power chair while it is in a moving vehicle. Personal injury and/or property damage may result.

WARNING! Always be sure your power chair and its batteries are properly secured when it is being transported. Failure to do so may result in personal injury and/or damage to your power chair.

II. SAFETY

Transfers

Transferring onto and off of your power chair requires a good sense of balance. Always have an attendant or healthcare professional present while learning to properly transfer yourself.

To eliminate the possibility of injury, Pride recommends that you or a trained attendant perform the following tasks before attempting a transfer:

- Turn off the power to the controller. See VII. "Operation."
- Ensure your power chair is not in freewheel mode. See III. "Your Power Chair."
- Turn both castor wheels toward the transfer destination to improve power chair stability during transfer.
- Make sure both armrests are flipped up or removed from your power chair.
- Move the leg rests aside; this will help to keep your feet from getting caught on the foot riggings during the transfer.
- Reduce the distance between your power chair and the object you are transferring onto.

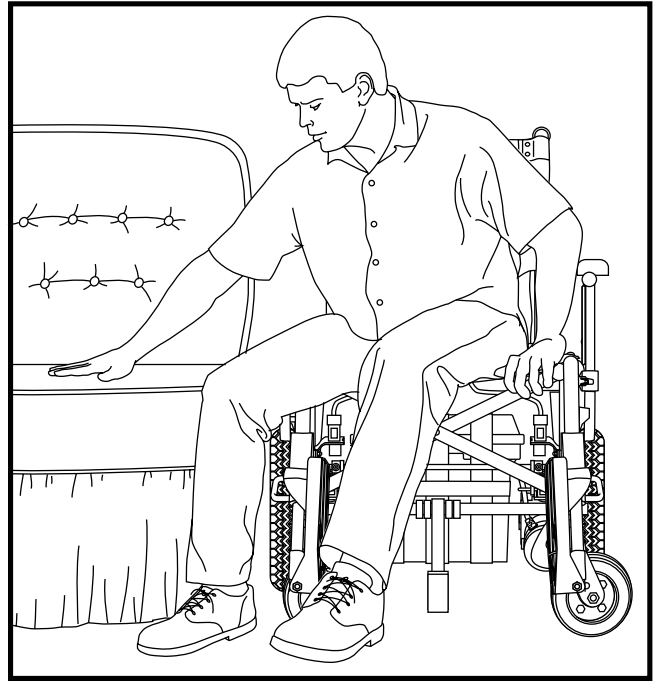

Figure 4. Ideal Transfer Position

WARNING! Before transferring, position yourself as far back as possible in the power chair seat to prevent the power chair from tipping forward during transfer and causing injury.



WARNING! Prevent personal injury and product damage! Avoid putting all of your weight on the power chair armrests and do not use the armrests for weight bearing purposes, such as transfers. Such use may cause the power chair to tip, resulting in a fall from the power chair

WARNING! Avoid putting all of your weight on the foot riggings. Such use may cause the power chair to tip and cause personal injury.

Positioning Belts

Your authorised Pride Dealer, therapist(s), and other healthcare professionals are responsible for determining your requirement for a positioning belt in order to operate your power chair safely. Typically, the positioning belt is not designed for use as a restraining device in a motor vehicle. If your power chair is not rated for use as a seat in a motor vehicle, then you should be properly belted into seats approved by the vehicle manufacturer with your power chair properly stowed for vehicle transport. If your power chair is rated for use as a seat in a motor vehicle, Pride recommends that you ensure your authorised dealer or healthcare professional has properly configured the power chair and positioning belt for such use.



MANDATORY! In order to verify that your power chair is rated for use as a seat in a motor vehicle, contact your authorised Pride Dealer.



WARNING! If you require a positioning belt to safely operate your power chair, make sure it is fastened securely each time you use your power chair. Serious personal injury may result if you fall from the power chair.

Lift/Elevation Products

If you will be traveling with your power chair, you may find it necessary to use a lift/elevation product to aid in transportation. Pride recommends that you closely review the instructions, specifications and safety information set forth by the manufacturer of the lift/elevation product before using that product.

II. SAFETY



WARNINGS! Never sit on your power chair when it is being used in connection with any type of lift/elevation product. Your power chair was not designed with such use in mind and any damage or injury incurred from such use is not the responsibility of Pride.

Reaching and Bending

Never reach, lean or bend while driving your power chair. If it is absolutely necessary to reach, lean or bend while seated on your power chair, it is important to maintain a stable centre of gravity and keep the power chair from tipping. Pride recommends that the power chair user determine his/her personal limitations and practice bending and reaching in the presence of a qualified healthcare professional.



WARNING! Do not bend, lean or reach for objects if you have to pick them up from the floor by reaching down between your knees. Movements such as these may change your centre of gravity and the weight distribution of the power chair. This may cause your power chair to tip, possibly resulting in personal injury.

WARNING! Prevent personal injury! Keep your hands away from the tyres when driving. Be aware that loose fitting clothing can become caught in drive tyres.

Preventing Unintended Movement



WARNING! If you anticipate being seated in a stationary position for an extended period of time, turn off the power. This will prevent unexpected motion from inadvertent joystick contact. This will also eliminate the possibility of unintended chair movement from electromagnetic (EMI) sources. Failure to do so may result in personal injury.

Batteries

In addition to following the warnings below, be sure to comply with all other battery handling information. For more information about your power chair's batteries, see VI. "Batteries and Charging."

WARNING! Power chair batteries are heavy. See specifications table. If you are unable to lift that much weight, be sure to get help. Lifting beyond your capacity can result in personal injury.



WARNING! Battery posts, terminals and related accessories contain lead and lead compounds. Wash hands after handling.

WARNING! Always protect the batteries from freezing and never charge a frozen battery. Charging a frozen battery may result in personal injury and/or damage to the battery.

Battery Disposal and Recycling

If you encounter a damaged or cracked battery, immediately enclose it in a plastic bag and call your authorised Pride Dealer for instructions on disposal. Your authorised Pride Dealer will also have the necessary information on battery recycling, which is our recommended course of action.

Prescription Drugs/Physical Limitations

Users must exercise care and common sense when operating a power chair. This includes awareness of safety issues when taking prescribed or over-the-counter drugs or when the user has specific physical limitations.



WARNING! Consult your physician if you are taking prescribed or over-the-counter medication or if you have certain physical limitations. Some medications and limitations may impair your ability to operate your power chair in a safe manner.

II. SAFETY

Alcohol

The power chair user must exercise care and common sense when operating his/her power chair. This includes awareness of safety issues while under the influence of alcohol.



WARNING! Do not operate your power chair while you are under the influence of alcohol, as this may impair your ability to operate your power chair in a safe manner.

Removable Parts



WARNING! Prevent personal injury and/or product damage! Do not attempt to lift or move a power chair by any of its removable parts, including the armrests, seat, foot riggings, shroud and controller.

Electromagnetic and Radio Frequency Interference (EMI/RFI)



WARNING! Laboratory tests have shown that electromagnetic and radio frequency waves can have an adverse affect on the performance of electrically-powered mobility vehicles.

Electromagnetic and Radio Frequency Interference can come from sources such as cellular phones, mobile two-way radios (such as walkie-talkies), radio stations, TV stations, amateur radio (HAM) transmitters, wireless computer links, microwave signals, paging transmitters and medium-range mobile transceivers used by emergency vehicles. In some cases, these waves can cause unintended movement or damage to the control system. Every electrically-powered mobility vehicle has an immunity (or resistance) to EMI. The higher the immunity level, the greater the protection against EMI. This product has been tested and has passed at an immunity level of 20 V/m.

WARNING! Be aware that cell phones, two-way radios, laptops and other types of radio transmitters may cause unintended movement of your electrically-powered mobility vehicle due to EMI. Exercise caution when using any of these items while operating your mobility vehicle and avoid coming into close proximity of radio and TV stations.



WARNING! The addition of accessories or components to the electrically-powered mobility vehicle can increase the susceptibility of the vehicle to EMI. Do not modify your power chair in any way not authorised by Pride.

WARNING! The electrically-powered mobility vehicle itself can disturb the performance of other electrical devices located nearby, such as alarm systems.

NOTE: For further information on EMI/RFI, go to the Resource Center on www.pridemobility.com. If unintended motion or brake release occurs, turn your power chair off as soon as it is safe to do so. Contact your authorised Pride Dealer to report the incident.

III. YOUR POWER CHAIR

THE PRIDE LX

The Pride LX is a rear-wheel drive power chair that you can easily disassemble and fold for transportation or storage. The Pride LX includes two armrests, a seatback and seat base, two motor/brake assemblies, two drive wheels, two anti-tip wheels, two castor wheels, two battery boxes and wiring harnesses. The two battery boxes sit inside the frame.



Figure 5. Pride LX Assembled

III. YOUR POWER CHAIR

SPECIFICATIONS	
Maximum Safe Slope:	8.7% (5°)
Maximum Climbing Ability:	8.7% (5°)
Maximum Obstacle Climbing Ability:	5 cm
Drive Wheels:	33 cm (13 in.) solid
Castor Wheels:	20 cm (8 in.) solid; articulating
Anti-tip Wheels:	5 cm (1.9 in.) solid; rear-mounted
Maximum Speed: ¹	6 km/h (4 mph)
Ground Clearance: ²	11.5 cm (4.5 in.)
Turning Radius: ²	84 cm (33 in.)
Overall Size: ²	Length: 109 cm (43 in.) Width: 65 cm (25.5 in.) Width: 32 cm (12.5 in.) folded
Seating Options:	Sling Back and Sling Seat
Drive Train:	Two-motor, rear-wheel
Brakes:	"Intelligent Braking" electronic regenerative
Range: ¹	Up to 40 km (25 miles)
Batteries:	Two 12-volt, 32 AH (AGM or Gel-Cell type recommended)
Battery Charger:	Off-board
Electronics:	Pilot Controller VSI Controller
Weight Capacity:	113 kg (17 stone; 250 lbs.)
Component Weights:	Base: 38 kg (83 lbs.) Batteries: 11 kg (24.5 lbs.) each

¹ Varies with user weight, terrain type, battery amp hour rating (AH), battery charge, battery condition and tyre condition.

² Due to manufacturing tolerances and continual product improvement, this specification can be subject to a variance of (+ or -) 3%.

NOTE: All specifications subject to change without notice.

III. YOUR POWER CHAIR

Electrical Connections

The controller is connected to the front battery box and to each motor. See figures 6 and 7. The motor connectors are marked “L” and “R”. The “L” harness is connected to the left motor and the “R” harness is connected to the right motor.

Battery Connections: The rear battery box is connected to the front battery box via the red connector. The front battery box is connected to the controller via the black connector. Each connector is labelled with a “+” on one side and a “-” on the other side.

Main Circuit Breakers: There are two 30-amp circuit breakers that protect the electrical circuits. Each circuit breaker is mounted on the side of each battery box. See figure 8. The circuit breaker is in-line with the positive (+) battery terminal. If the batteries and the motors are heavily strained (e.g., from excessive loads), these circuit breakers will trip to prevent damage to the motors and the electronics. If either of the circuit breakers trip, allow the LX to “rest” for approximately one minute. Then, push in the circuit breaker button, turn on the controller power and continue normal operation. If either circuit breaker continues to trip repeatedly, contact your authorised Pride Dealer.

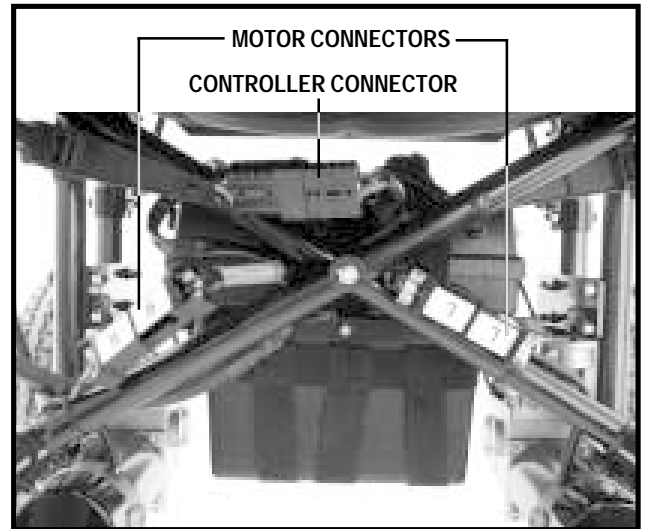

Figure 6. Front Electrical Connections



Figure 7. Rear Battery Box

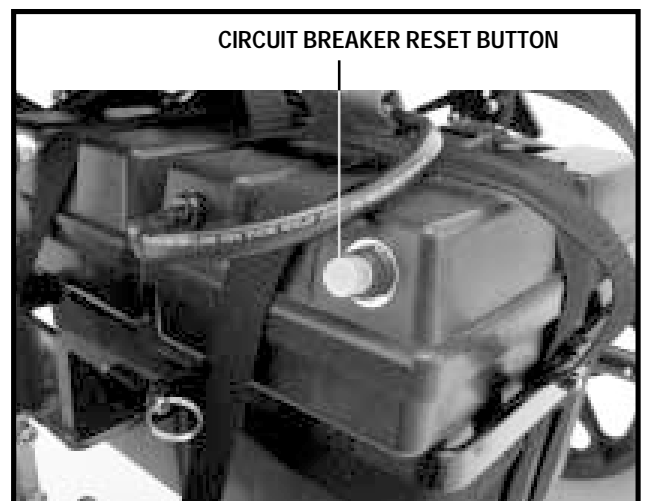

Figure 8. Rear Circuit Breaker

III. YOUR POWER CHAIR

Brake Release Levers

For convenience, your power chair is equipped with two manual brake release levers that enable you to disengage the drive motors and manoeuvre the chair manually in freewheel mode.

To engage or disengage the drive motors:

1. Locate the manual brake release levers on each motor. See figures 9 and 10.
2. Rotate the manual brake release levers outward to disengage the drive wheels. See figure 9.
3. Rotate the manual brake release levers rearward to engage the drive wheels. See figure 10.

If a lever is difficult to move in either direction, rock the power chair gently back and forth while turning the levers. The lever should then move to the desired position.

NOTE: *It is important to remember that when your power chair is in freewheel mode, the braking system is disengaged.*

WARNING! Do not use your power chair in freewheel mode without an attendant present. Personal injury may result.



WARNING! Do not attempt to personally place your power chair in freewheel mode while seated in it. Personal injury may result. Ask your attendant for assistance.

WARNING! Do not place your power chair in freewheel mode while on an incline. The chair could roll uncontrollably on its own, causing personal injury.

Manual Parking Brake

Your power chair is equipped with manual parking brake levers that enable you to lock the drive wheels when stopped.

To engage or disengage the manual parking brake:

1. Locate the manual parking brake lever on each motor. See figure 11.
2. Push the manual parking brake lever forward to engage the parking brake.
3. Pull the manual parking brake lever rearward to disengage the parking brake.



Figure 9. Drive Motors Disengaged (Freewheel Mode)

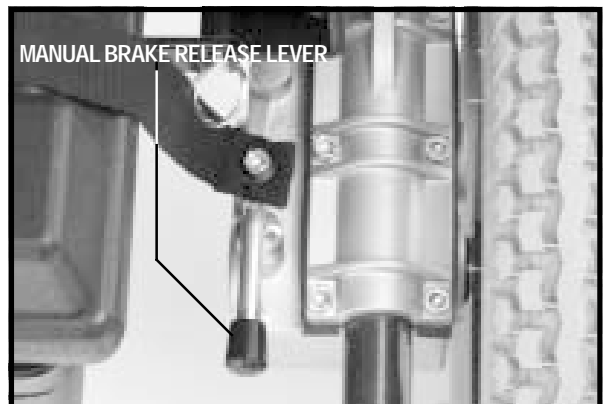

Figure 10. Drive Motors Engaged (Drive Mode)

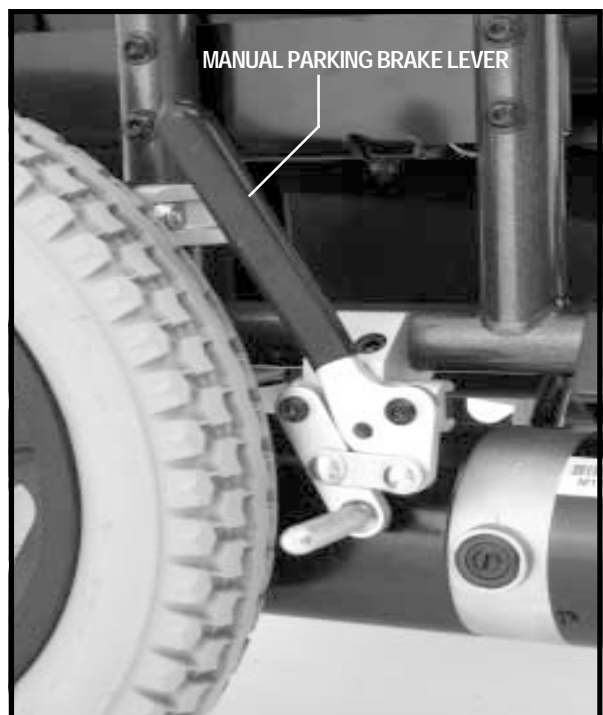

Figure 11. Manual Parking Brake (Disengaged)

IV. ASSEMBLY/DISASSEMBLY

ASSEMBLY

The contents of your Pride LX box are as follows: one (1) base assembly, one (1) seatback, two (2) battery boxes, one (1) controller box, one (1) battery charger box and one (1) accessories box. The accessories box contains: one (1) battery frame, four (4) battery tray ball detent pins, one (1) toolkit, six (6) tie-wraps, two (2) anti-tip wheels, and two (2) swing-away leg rests. Remove the components from the shipping box and take inventory. If any parts are missing, contact your authorised Pride Dealer immediately. See figure 12.

The toolkit contains all of the tools that you will need for assembly and can be stored inside the seatback pocket. It contains the following:

- | | | |
|------------------|-----------------|----------------|
| ■ socket adapter | ■ socket handle | ■ 8-mm socket |
| ■ 10-mm socket | ■ 12-mm socket | ■ 13-mm socket |
| ■ 5-mm hex bit | ■ 4-mm hex bit | ■ 3-mm hex bit |

To assemble the Pride LX:

1. Unfold the seat base assembly.
2. Install each battery into a battery box. See figure 13. Connect the red cable to the positive (+) battery terminal and the white cable to the negative (-) battery terminal.
3. Install the battery frame. See figure 14. Make sure the tabs are facing upwards so that the middle of the tray can only fold up.
4. Install the battery boxes into the battery frame. Make sure that both main circuit breakers are on the right side of the base assembly.

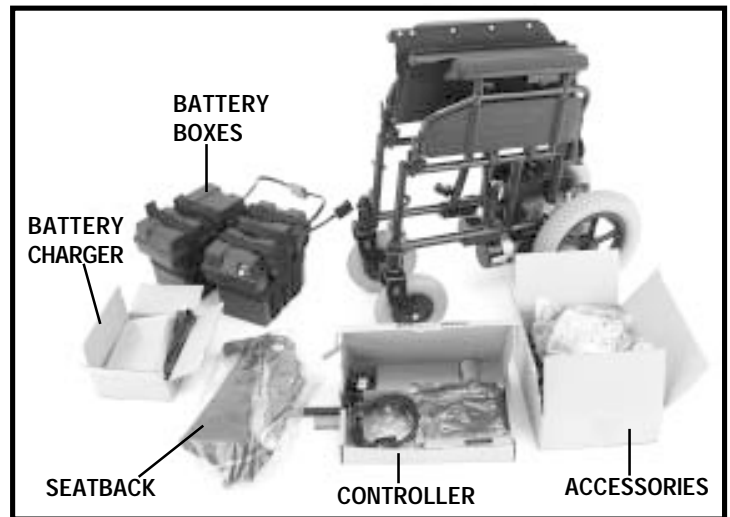

Figure 12. Pride LX Components

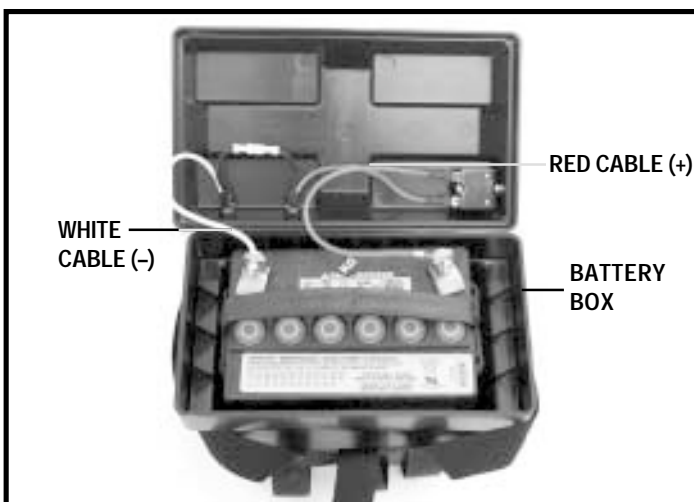

Figure 13. Battery Installation

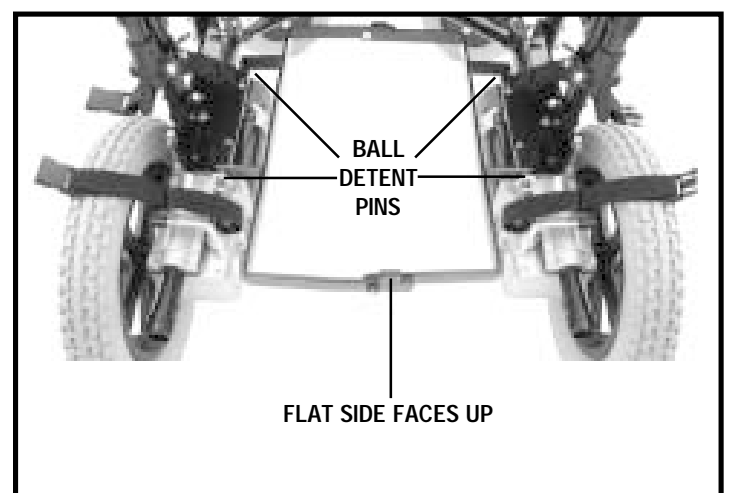

Figure 14. Battery Frame Installation

IV. ASSEMBLY/DISASSEMBLY

5. Connect the two red connectors. See figure 15.
6. Connect the straps to secure the battery boxes. Adjust for tightness as necessary. See figure 15.
7. Remove the plastic wrap from the seatback posts and remove the seatback screws. See figure 15.
8. Flip up the armrests.
9. Unfold the seatback and insert the canes into the base assembly. The smaller pouch faces rearward. You may store the toolkit in this smaller pouch.
10. Insert the seatback screws into the seat canes with the screw head on the inside. See figure 16.
11. Install two tie-wraps to secure the seatback. See figure 17.
12. Insert the controller into the armrest and tighten the securement knob. See figure 19.

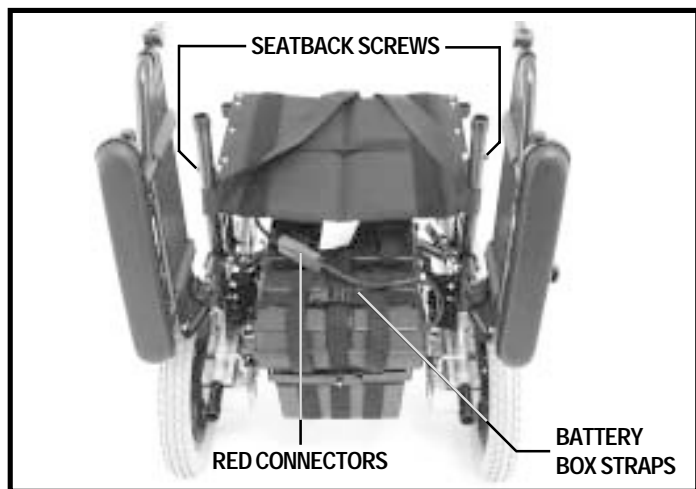

Figure 15. Pride LX Rear View

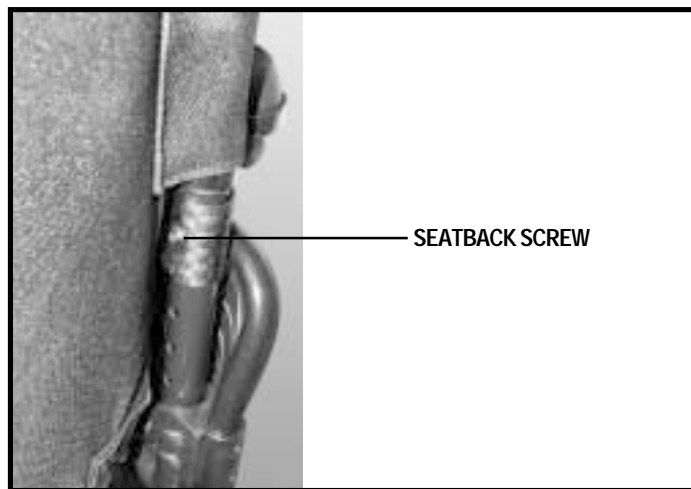

Figure 16. Seatback Screw Installation

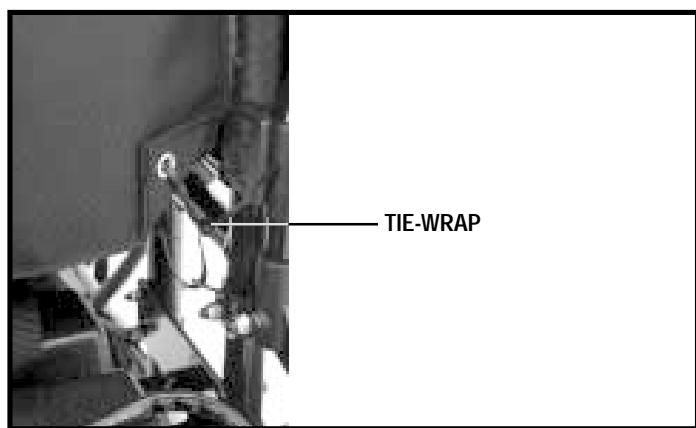

Figure 17. Tie-Wrap Installation



Figure 18. Controller Profile (VSI Shown)

IV. ASSEMBLY/DISASSEMBLY

13. Connect the controller to the motors. The motor connectors are marked “L” for left and “R” for right. Match the “L” on the controller connector with the “L” on the motor. Match the “R” on the controller connector with the “R” on the motor. Connect the black connector to the controller connector. See figure 6.



WARNING! Do not place the controller cable so that it can be pinched in the seat frame or the power base frame.

14. Install the foot riggings. See figure 20.
15. Press the silver button on the anti-tip bracket and install the anti-tip wheels. See figure 21.
16. Remove the off-board battery charger from the box and plug it into the off-board charger port. Refer to VI. “Batteries and Charging” for more information.
17. Read this owner’s manual thoroughly before operating your power chair.

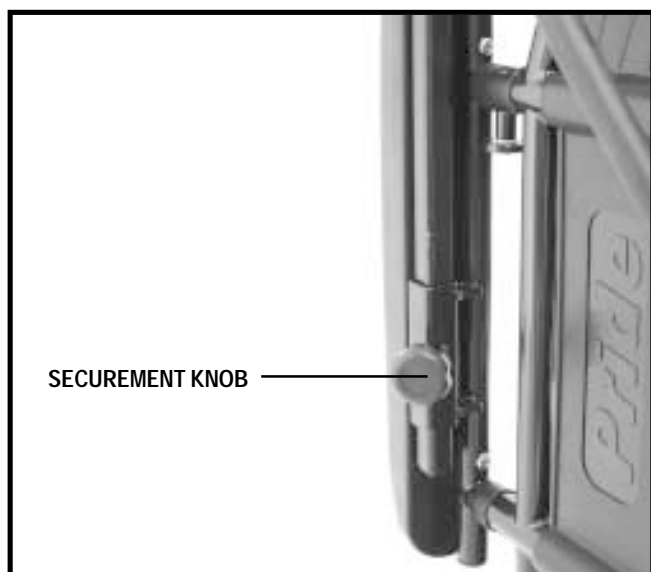

Figure 19. Controller Installation



Figure 20. Foot Rigging Installation

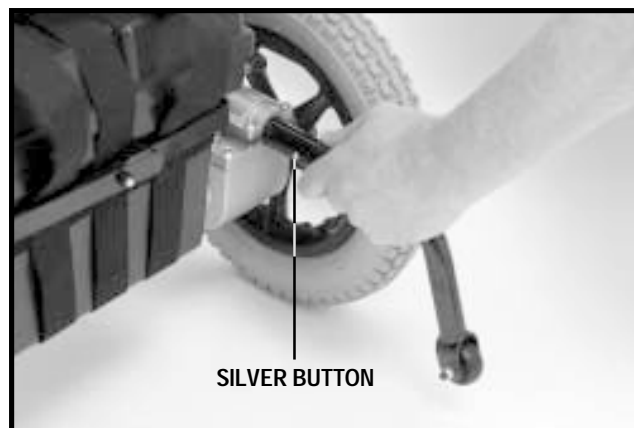

Figure 21. Anti-tip Installation



Figure 22. Charging the Batteries

IV. ASSEMBLY/DISASSEMBLY

DISASSEMBLY

Your Pride LX is a folding chair. Once you remove the two battery boxes, you can fold the chair for easy transportation and storage.

To disassemble and fold your Pride LX:

1. Disconnect the electrical connections. See figures 6 and 7.
2. Place the power chair in freewheel mode. See figure 9.
3. Unstrap the battery boxes.
4. Lift the battery boxes off of the frame.
5. Flip up and remove the foot plates
6. Pull up the middle of the battery frame. See figure 23.
7. Push down on the seat cane release levers and fold down the seat canes. See figure 24.
8. Grab the seat base and pull up the seat.

To assemble and expand your power chair:

1. Push down on the seat base bars until they lock into place. See figure 25.
2. Flip up the seat canes and lock them into place.
3. Place the front battery box onto the frame, slide it forward and connect the battery box straps.
4. Place the rear battery box onto the frame and connect the battery box straps.
5. Connect the controller to the front battery box.
6. Connect the front battery box to the rear battery box.
7. Place the power chair into drive mode. See figure 10.

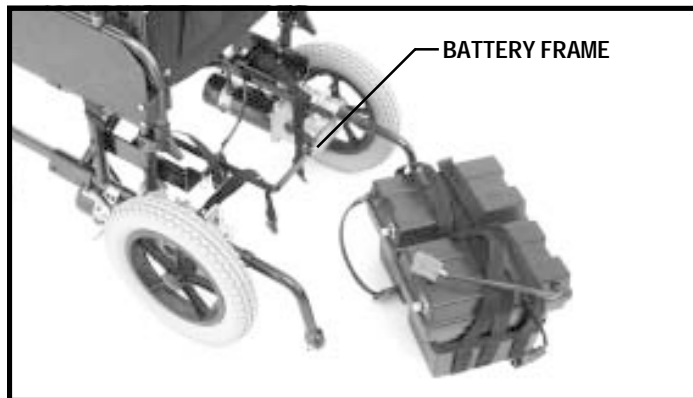

Figure 23. Pride LX - Battery Boxes Removed



Figure 24. Seat Cane Release Lever



Figure 25. LX - Disassembled and Folded

V. COMFORT ADJUSTMENTS

COMFORT ADJUSTMENTS

After becoming familiar with your power chair's operation, you may find the need to make some adjustments to increase your comfort, such as seatback height, armrest height, foot rigging length and controller position.

WARNING! If your power chair was configured by your authorised Pride Dealer, please consult your healthcare professional before changing the seat position or making any other adjustment. Some adjustments may degrade your power chair's performance and safety by changing its centre of gravity.



WARNING! Some power chair components are heavy. You may need assistance to lift or carry them. Please refer to the specifications table for specific component weights before you disassemble the power chair.

WARNING! Prevent injury. Remove the occupant from the power chair before making any adjustments.

Seatback Height Adjustment

You can change the seatback height to one of five different positions in 2.5-cm (1-in.) increments.

To change the seatback height:

1. Remove the screws that attach the canes to the frame. See figures 15 and 26.
2. Depending on the position of the seat and the length of the tie-wrap, you may have to cut the tie-wraps that fasten the seatback to the frame. See figure 26.
3. Move the seat canes up or down to adjust the seatback height.
4. Reinstall the seatback screws.
5. Install one tie-wrap on each side of the seatback.

Armrest Height Adjustment

You can change the armrest height to one of five different positions in 2.5-cm (1-in.) increments.

To change the armrest height:

1. Pull out the armrest release pin to release the armrest. See figure 27.
2. Move the armrest up or down to the desired height.
3. Release the pin to lock the armrest.

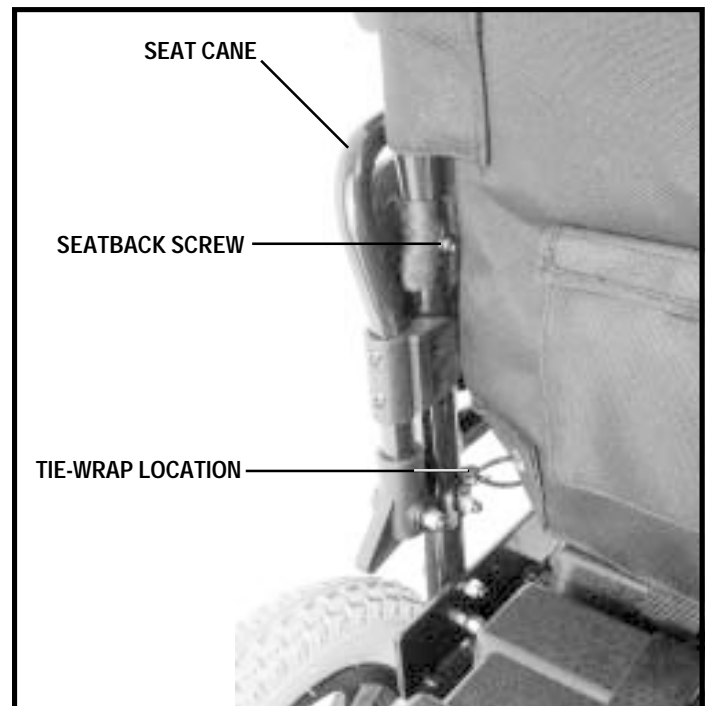

Figure 26. Seatback



Figure 27. Armrest Height Adjustment

V. COMFORT ADJUSTMENTS

Swing-Away Footrest Length

You can change the footrest length in 2.5-cm (1-in.) increments.

To change the footrest length:

1. Loosen the footrest setscrew. See figure 28.
2. Slide the footrest up or down to the desired length.
3. Tighten the setscrew.
4. Repeat for the other side.

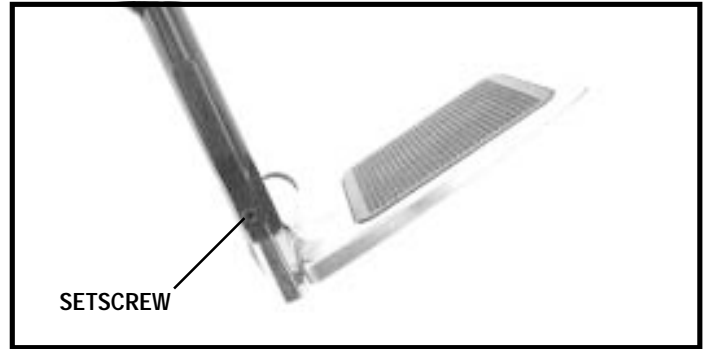

Figure 28. Swing-away Footrest

Controller Extension

You may change the position of the controller by sliding it in or out of its bracket. See figure 29.

To change the controller position:

1. Loosen the securement knob.
2. Slide the controller in or out to the desired position.
3. Tighten the securement knob.

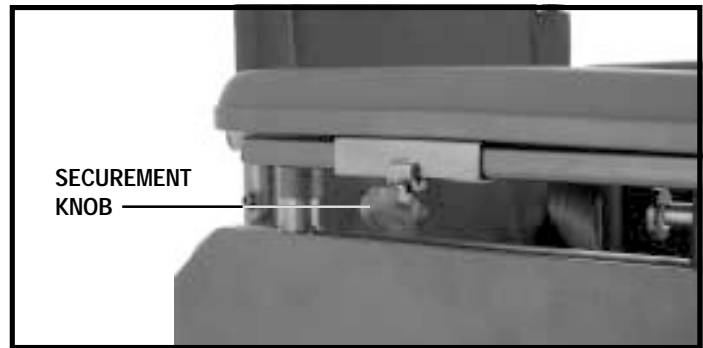

Figure 29. Controller Extension

Changing the controller from the right armrest to the left armrest requires a different bracket. See your authorised Pride Dealer.

Positioning Belt

Your power chair is equipped with an automotive-type positioning belt that can be adjusted for operator comfort. The positioning belt is designed to prevent the operator from sliding down or forward in the seat. The positioning belt is not designed for use as a restraining device.

To remove/install the positioning belt:

1. Remove the seatback screws that attach the seat canes to the frame. See figures 26.
2. Cut the tie-wraps that fasten the seatback to the frame.
3. Remove the seat canes.
4. Slip each end of the belt up and over the frame. See figure 30.
5. Reinstall the seatback screws.
6. Install one tie-wrap on each side of the seatback.

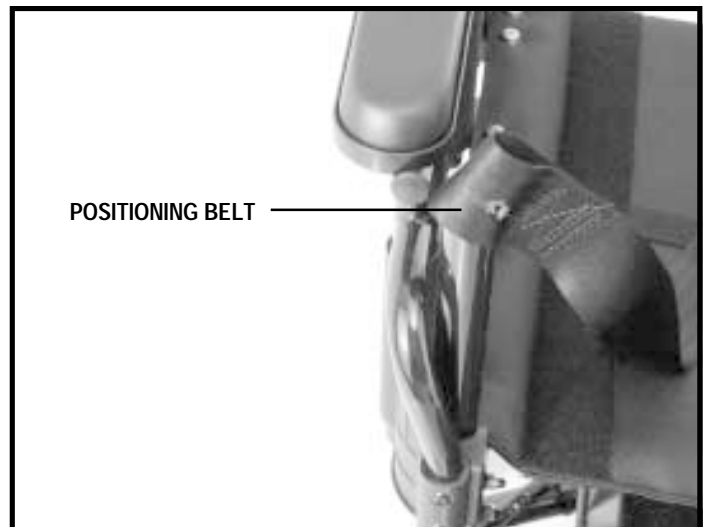

Figure 30. Positioning Belt Removal/Installation

V . C O M F O R T A D J U S T M E N T S

To adjust the positioning belt:

1. When seated, insert the metal tab into the plastic housing on the opposite strap until you hear a click.
2. Pull the strap until it is secure, but not so tight as to cause discomfort.

MANDATORY! Prevent personal injury! Make sure the positioning belt is properly secured to the power chair and is adjusted for operator comfort before each use.



MANDATORY! Prevent personal injury and product damage! Inspect the positioning belt for loose or damaged parts before each use of the power chair. If you discover a problem, contact your authorised Pride Dealer for maintenance and repair.

VI. BATTERIES AND CHARGING

BATTERIES AND CHARGING

The power chair uses two long-lasting, 12-volt, deep-cycle batteries that are sealed and maintenance-free. Since they are sealed, there is no need to check the electrolyte (fluid) level. Deep-cycle batteries are designed to handle a deep discharge. Though they are similar in appearance to automotive batteries, they are not interchangeable. Automotive batteries are not designed to handle a long, deep discharge and also are unsafe for use in power chairs.

WARNING! Battery posts, terminals and related accessories contain lead and lead compounds. Wash hands after handling.



WARNING! Prevent injury and/or equipment damage! Do not use batteries that exceed the recommended type and amp-hour capacity. Do not use batteries with different amp-hour capacities. Refer to specifications table in this manual and in the manual supplied with the battery charger for recommended type and capacities.

NOTE: For more information on battery charging, refer to the operation manual supplied with your battery charger.

Charging the Batteries

The battery charger is essential in providing long life for your power chair batteries. It is designed to optimise your power chair's performance by charging the batteries safely, quickly and easily.



PROHIBITED! Removal of grounding prong can create electrical hazard. If necessary, properly install an approved 3-pronged adapter to an electrical outlet having 2-pronged plug access. Failure to heed could result in personal injury and/or property damage.

PROHIBITED! Never use an extension lead to plug in your battery charger. Plug the charger directly into a properly wired standard electrical outlet.

WARNING! You must recharge your power chair's batteries with the supplied off-board battery charger. Do not use an automotive-type battery charger.

WARNING! Prevent injury and/or equipment damage! Read the battery charging instructions in this manual and in the manual supplied with the battery charger before charging the batteries.

WARNING! Prevent injury and/or equipment damage! Do not expose the off-board battery charger to rain or other sources of moisture unless it has been tested for outdoor use. Refer to the manual supplied with the battery charger for more information.



WARNING! Prevent injury and/or equipment damage! Explosive gases may be generated while charging the batteries. Keep the power chair and the battery charger away from sources of ignition such as flames or sparks and provide adequate ventilation when charging the batteries.

WARNING! Prevent injury and/or equipment damage! Inspect the battery charger, wiring and connectors for damage before each use. Contact your authorised Pride Dealer if damage is found.

WARNING! Prevent injury and/or equipment damage! Do not attempt to open the battery charger case. If the battery charger does not appear to be working correctly, contact your authorised Pride Dealer.

WARNING! Prevent injury and/or equipment damage! If the off-board battery charger is equipped with cooling slots, then do not attempt to insert objects through these slots.

WARNING! Prevent injury and/or equipment damage! Do not allow unsupervised children to play near the power chair while the batteries are charging.

VI. BATTERIES AND CHARGING



WARNING! Prevent injury and/or equipment damage! If your off-board battery charger has not been tested and approved for outdoor use, then do not expose it to adverse or extreme weather conditions. If the battery charger is exposed to adverse or extreme weather conditions, then it must be allowed to adjust to the difference in environmental conditions before use indoors. Refer to the manual supplied with the battery charger for more information.

To charge the batteries using the off-board charger:

1. Position the front of your power chair next to a standard electrical outlet.
2. Turn off the power to the controller.
3. Plug the off-board charger into the off-board charger port on the front of the controller. See figure 5.
4. Plug the off-board charger into the electrical outlet.

NOTE: *If it is a Pride off-board charger, then there are two lights in it. The red light indicates that power to the off-board charger is on. The green light indicates that the batteries are fully charged. If it is not a Pride off-board charger, then follow the instructions supplied by the manufacturer.*

5. When the batteries are fully charged, unplug the off-board charger from the electrical outlet and then from the off-board charger port.

Battery Break-in

To break in new batteries for maximum efficiency:

1. Fully recharge any new battery prior to its initial use. This will bring the battery up to about 90% of its peak performance.
2. Operate your power chair about the house and grounds. Move slowly at first and do not travel too far until you become accustomed to the controls and break-in the batteries.
3. Give the batteries another full charge of 8 to 14 hours and run the power chair again. The batteries will now perform at over 90% of their potential.
4. After four or five charging cycles, the batteries will top off at 100% charge and last for an extended period.

Frequently Asked Questions (FAQs)

Can I use a different battery charger?

You should use the charger supplied with the power chair. It is the safest, most efficient tool to charge the batteries. We do not recommend using other types of chargers (e.g., an automotive battery charger).

How often must I charge the batteries?

Many factors come into play when deciding how often to charge the batteries. You may use your power chair all day on a daily basis or you may not use it for weeks at a time.

■ **Daily Use**

If you use your power chair on a daily basis, charge the batteries as soon as you are finished using your power chair. Your power chair will be ready each morning to give you a full day's service. It is recommended that you charge the batteries 8 to 14 hours after daily use.

■ **Infrequent Use**

If you use your power chair infrequently (once a week or less), you should charge the batteries at least once per week for 12 to 14 hours.

VI. BATTERIES AND CHARGING

NOTE: *Keep your batteries fully charged and avoid deeply discharging your batteries. Do not charge the batteries for more than 24 hours at a charging cycle.*

How can I get maximum range or distance per charge?

Rarely do you have an ideal driving situation such as smooth, flat, hard terrain with no wind, hills or curves. More often you are presented with hills, pavement cracks, uneven and loosely packed surfaces, curves and wind. All of these factors will affect the distance or running time per battery charge. Below are a few suggestions for obtaining the maximum range per charge:

- Always charge the batteries fully prior to your trip.
- Plan your trip in advance to avoid inclines if possible.
- Limit baggage weight to essential items.
- Try to maintain an even speed and avoid stop-and-go driving.

What type of batteries should I use?

We recommend deep-cycle batteries that are sealed and maintenance free. Both AGM and Gel-Cell are deep-cycle batteries that are similar in performance. Refer to the specifications table for more information regarding the batteries used with your power chair.



WARNING! Corrosive chemicals contained in batteries. Use only AGM or Gel-Cell batteries to reduce the risk of leakage or explosive conditions.

Why do my new batteries seem weak?

Deep-cycle batteries employ a much different chemical technology than that used in car batteries, nickel-cadmium (nicads) or in other common battery types. Deep-cycle batteries are specifically designed to provide power, drain down their charge and then accept a relatively quick recharge. AGM and Gel-Cell batteries should be charged as often as possible. They do not have a “memory” like nickel-cadmium batteries.

We work closely with our battery manufacturer to provide a battery that best suits your power chair’s specific demands. Fresh batteries arrive regularly at Pride and are promptly shipped with a full charge. During shipping, the batteries encounter temperature extremes that may influence initial performance. Heat robs the charge from the battery, and cold slows the power available and extends the time needed to recharge the battery (just as with a car battery).

It might take a few days for the temperature of the battery to stabilise and adjust to its new ambient temperature. More importantly, it will take a few “charging cycles” (a partial drain—then a full recharge) to establish the critical chemical balance that is essential to the battery’s peak performance and long life. It will be well worth it to take the time to break in your battery properly.

NOTE: *The useful life of a battery is quite often a reflection of the care it receives.*

How can I ensure maximum battery life?

A fully charged deep-cycle battery will provide reliable performance and extended battery life. Keep your power chair’s batteries fully charged whenever possible. Batteries that are regularly and deeply discharged, infrequently charged or stored without a full charge may be permanently damaged, causing unreliable power chair operation and limited battery life.

VI. BATTERIES AND CHARGING

How should I store my power chair and its batteries?

If you do not use your power chair regularly, we recommend maintaining battery vitality by charging the batteries at least once per week.

If you do not plan on using your power chair for an extended period, fully charge the batteries prior to storage. Disconnect the battery harnesses and store the power chair in a warm, dry environment. Avoid temperature extremes, such as freezing and excessively hot conditions, and never attempt to charge a frozen battery. A cold or frozen battery should be warmed for several days prior to recharging.

What about public transport?

AGM and Gel-Cell batteries are designed for application in power chairs and other mobility vehicles, allowing safe transport on aircraft, buses and trains, as there is no danger of spillage or leakage. We suggest you contact the carrier's ticket counter in advance to determine that carrier's specific requirements.

What about shipping?

If you wish to use a freight company to ship your power chair to your final destination, repack your power chair in the original shipping container and ship the batteries in separate boxes.

VII. OPERATION

THE PILOT CONTROLLER

The electronic controller is what you use to operate your power chair. It takes the battery voltage and sends it to the appropriate system. The electronic controller also enables you to monitor battery capacity, electronic controller functions and the condition of your electrical system. The Pilot electronic controller is an integral electronic controller. All of the electronics necessary to operate your power chair are contained in one module. See figure 31. Typically, the Pilot is mounted to one of the armrests and is connected to the motors and batteries at the electronics tray.

The controller supplied with your power chair has been pre-programmed to meet your needs. The program is set using either a personal computer with software provided by the controller manufacturer or with a hand-held programmer, also provided by the controller manufacturer.



WARNING! The controller program can affect speed, acceleration, deceleration and braking. If it is programmed incorrectly or outside of the safe limits as determined by your healthcare professional, it can create a dangerous situation. Only the power chair manufacturer, an authorized representative of the manufacturer or a trained service technician should program the controller.

The Pilot controller consists of:

1. joystick
2. on/off button
3. battery condition meter
4. speed control knob
5. off-board charger/programming socket
6. controller connector
7. motor connectors

Joystick

The joystick controls the direction and speed of your power chair. When you move the joystick from the neutral (centre) position, the electromagnetic brakes release and allow your power chair to move. The farther you push the joystick from its neutral position, the faster your power chair moves. When you release the joystick and allow it to return to the neutral position, you engage the electromagnetic brakes. This causes your power chair to decelerate and come to a complete stop.

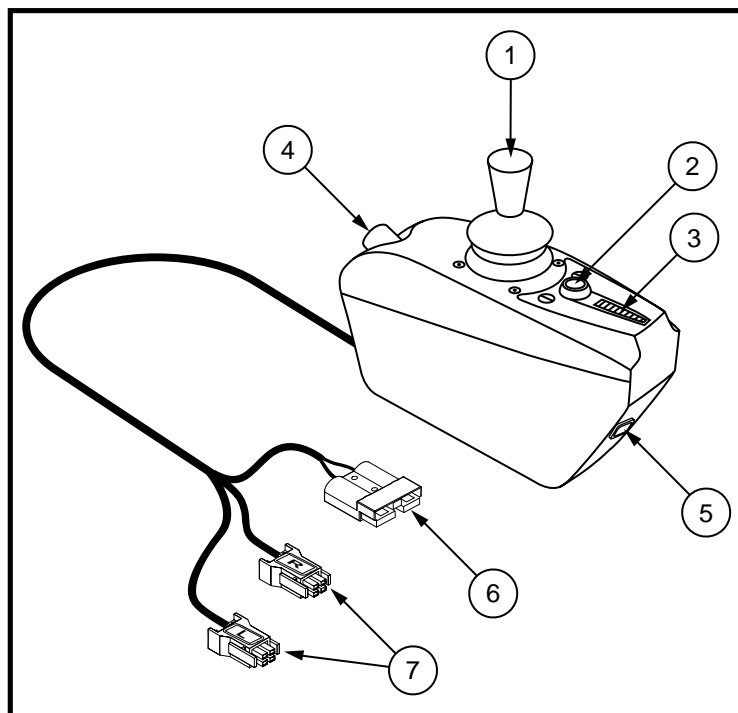

Figure 31. Pilot Controller



WARNING! If your power chair begins to move in an unexpected manner, immediately release the joystick. Unless the joystick is damaged, this action should stop your power chair.

On/Off Button

This is a green button located in front of the joystick. It turns the Pilot on and off.



WARNING! Unless faced with an emergency situation, do not use the on/off button to stop the chair. This will cause the power chair to stop abruptly.

WARNING! Always turn the power off when you are stationary to prevent unexpected movement.

V I I . O P E R A T I O N

Battery Condition Meter

The battery condition meter is located in front of the joystick. This is a 10-segment illuminated display that indicates that the Pilot is powered on and also gives the battery status, the Pilot status and the electrical system status.

- **Red, yellow and green lights lit:** Batteries charged; Pilot and electrical system OK.
- **Red and yellow lights lit:** Charge batteries if possible; Pilot and electrical system OK.
- **Red lights only lit or slow flash:** Charge batteries as soon as possible; Pilot and electrical system OK.
- **Rapid flash of lights:** Indicates a fault in the Pilot or the electrical system. Refer to “Pilot Error Codes.”
- **Ripple up and down of lights:** The joystick was not in the neutral position when the controller was turned on. If you get “ripple up and down of lights,” turn off the controller, allow the joystick to return to the neutral position, then turn on the controller.

NOTE: If you still get “ripple up and down of lights,” contact your authorised Pride Dealer.

NOTE: When the batteries approach a discharged state, the first red light will begin to slowly flash, reminding you the batteries need to be charged immediately!

Speed Control Knob

Sets the maximum speed of the power chair: clockwise to increase, anticlockwise to decrease.

NOTE: We recommend that the first few times you operate your power chair, you turn the speed control to the slowest setting until you become familiar with your new power chair.

Off-board Charger/Programming Socket

You may use an off-board charger to charge the power chair batteries through the 3-pin socket located on the front of the Pilot. If you use an off-board charger, the charger current should not exceed 8 amps. Contact your authorised Pride Dealer for more information.



WARNING! Only chargers with Neutrik NC3MX plugs should be connected to the off-board charger/programming socket. See your authorised Pride Dealer for more information.

NOTE: The off-board charger/programming socket may also be used for reprogramming the Pilot. Contact your authorised Pride Dealer for more information.

Controller Connector

This connects the Pilot to the power chair’s batteries, motors and motor brakes.

Motor Connectors

These connect the Pilot to the power chair’s motors and motor brakes.

VII. OPERATION

Thermal Rollback

The Pilot is equipped with a thermal rollback circuit. This circuit monitors the temperature of the motors and the Pilot. In the event that either one of the motors or the Pilot becomes excessively hot (above 50°C/122° F), the Pilot reduces the motor voltage. For every degree above 50°C (122° F), the controller reduces the voltage by 5 volts. This reduces your power chair's speed and allows the electrical components to cool down. When the temperature returns to a safe level, your power chair resumes its normal speed.



WARNING! Under strenuous driving conditions, it is possible for the bottom and side case temperature of the Pilot to exceed 40.56°C (105° F). DO NOT touch the side or bottom of the Pilot case under these circumstances.

Trouble Codes

In addition to indicating the current state of battery charge, the battery condition meter can also indicate possible problems with your power chair. The battery condition meter has ten lights. The lights provide information by the number of lights that are flashing. If any of the meter lights are flashing rapidly, the controller may be indicating a fault. For instance, if the first light is flashing rapidly, the battery voltage is nearly depleted. The following is a list of the possible errors signified by the rapidly flashing meter. When you get a trouble code, contact your authorised Pride Dealer.

FLASHING LIGHTS	DIAGNOSIS	SOLUTION
10	High Battery Voltage	Check batteries.
9	Solenoid Brake Fault	Check motor/brake wiring.
8	Possible Controller Fault	See authorised Pride Dealer.
7	Possible Joystick Fault	See authorised Pride Dealer.
6	Inhibit Active	Unplug charger. Check connections.
5	Right Motor Wiring Fault	Check right motor wiring.
4	Right Motor Disconnected	Check right motor wiring.
3	Left Motor Wiring Fault	Check left motor wiring.
2	Left Motor Disconnected	Check left motor wiring.
1	Low Battery Voltage	Check batteries/battery wiring.

VII. OPERATION

VSI ELECTRONIC CONTROLLER

The electronic controller is what you use to operate your power chair. The electronic controller enables you to move the power chair, as well as monitor battery charge, electronic controller functions, and the condition of your electrical system. The VSI is an integral electronic controller. All of the electronics necessary to operate the power chair are contained in one module. See figure 32. Typically, the VSI is mounted to one of the armrests and is connected to the motors, batteries and the off-board battery charger at the power base. The VSI may be used to control some optional systems such as power elevating seats and lights.

The controller supplied with your power chair has been pre-programmed to meet your needs. The program is set using either a personal computer with software provided by the controller manufacturer or with a hand-held programmer, also provided by the controller manufacturer.



WARNING! The controller program can affect speed, acceleration, deceleration and braking. If it is programmed incorrectly or outside of the safe limits as determined by your healthcare professional, it can create a dangerous situation. Only the power chair manufacturer, an authorised representative of the manufacturer, or a trained service technician should program the controller.

The VSI consists of:

1. joystick
2. keypad
3. off-board charger/programming socket
4. 2-pin battery connector
5. left motor connector
6. right motor connector

Joystick

The joystick controls the direction and speed of your power chair. When you move the joystick from the neutral (centre) position, the electromagnetic brakes release and allow your power chair to move. The farther you push the joystick from its neutral position, the faster your power chair moves. When you release the joystick and allow it to return to the neutral position, you engage the electromagnetic brakes. This causes your power chair to decelerate and come to a complete stop.



WARNING! If your power chair begins to move in an unexpected manner, immediately release the joystick. Unless the joystick is damaged, this action should stop your power chair.

Keypad

The keypad is located in front of the joystick. It contains keys necessary to operate your power chair. See figure 33.

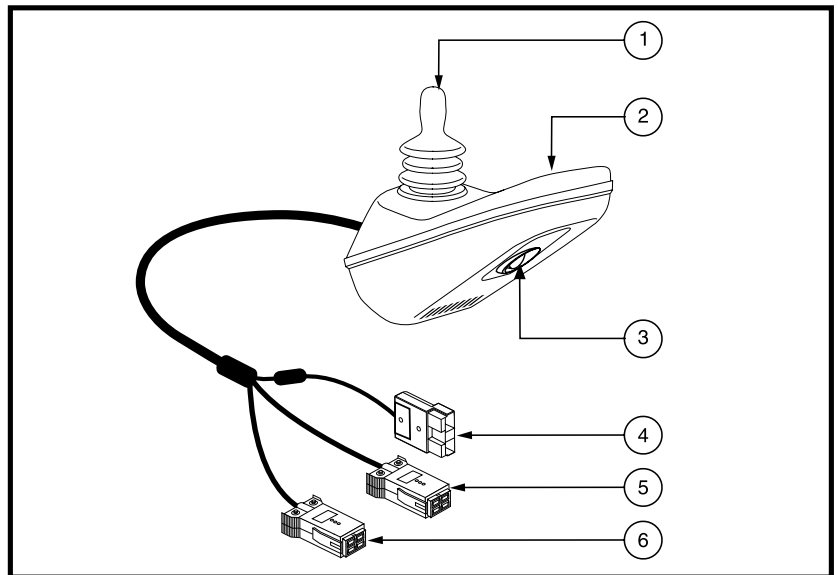

Figure 32. VSI Controller

VII. OPERATION

On/Off Key

The on/off key turns the VSI on and off.

WARNING! Unless faced with an emergency situation, do not use the on/off key to stop the power chair. This will cause the power chair to stop abruptly.



WARNING! Always turn the power off when you are stationary to prevent unexpected movement.

Battery Condition Meter

The battery condition meter is a 10-segment illuminated display located in front of the joystick. It consists of red, yellow and green lights. When the lights are on, it indicates that there is power to the VSI. The lights also indicate battery status, VSI operational status and electrical system status.

- **Red, yellow, and green lights lit:** Batteries charged; VSI operational and electrical system OK.
- **Red and yellow lights lit:** Charge batteries if possible; VSI operational and electrical system OK.
- **Red lights only lit or slow flash:** Charge batteries as soon as possible; VSI operational and electrical system OK.

NOTE: When the batteries approach a discharged state, the first red light will begin to slowly flash, reminding you the batteries need to be charged immediately!

- **Rapid flash of lights:** Indicates a fault in the VSI or the electrical system. Refer to “VSI Error Codes.”
- **Ripple side to side of lights:** The joystick was not in the neutral position when the controller was turned on. If you get “ripple side to side of lights,” turn off the controller, allow the joystick to return to the neutral position, then turn on the controller.

NOTE: If you still get “ripple side to side of lights,” contact your authorised Pride Dealer.

Speed/Profile Keys

The speed/profile keys control either the speed setting or the drive profile. Press the speed/profile increase key to increase the speed setting or change the drive profile to a higher number. Press the speed/profile decrease key to decrease the speed setting or change the drive profile to a lower number. The speed setting or drive profile is displayed on the maximum speed/profile indicator. If your power chair was programmed with a drive profile, contact your authorised Pride Dealer for more information.

NOTE: We recommend that the first few times you operate your power chair, you use the lowest speed setting until you become familiar with your new power chair.

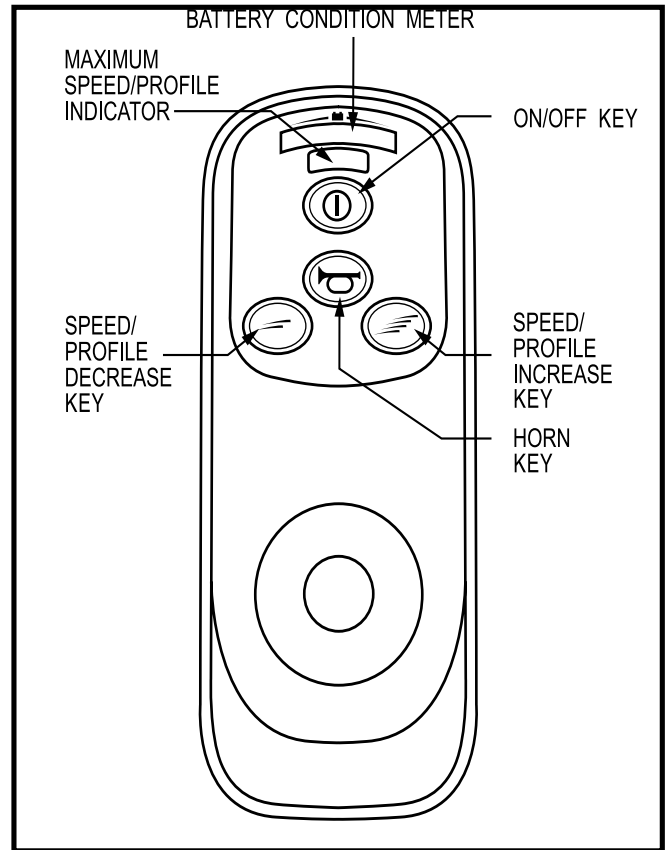

Figure 33. VSI Controller Keypad

VII. OPERATION

Horn Key

The horn key activates the horn.

Locking/Unlocking the VSI

The VSI has a feature that enables you to lock your power chair to prevent unauthorised use.

To lock the VSI:

1. With the VSI switched on, press and hold the on/off key. After 1 second, the VSI should beep.
2. Release the on/off key.
3. Push the joystick to the full forward position until the VSI beeps.
4. Pull the joystick to the full rearward position until the VSI beeps.
5. Release the joystick. There should be a long beep.
6. The VSI is now locked.

To unlock the VSI:

1. Press the on/off key to power on the VSI. The maximum speed/profile indicator should ripple side to side.
2. Push the joystick to the full forward position until the VSI beeps.
3. Pull the joystick to the full rearward position until the VSI beeps.
4. Release the joystick. There should be a long beep.
5. The VSI is now unlocked.

NOTE: *If the above procedure fails to either lock or unlock the VSI, contact your authorised Pride Dealer.*

Off-board Charger/Programming Socket

The off-board charger/programming socket is located on the front of the VSI. If you use an off-board charger, the charger current should not exceed 8 amps. Contact your authorised Pride Dealer for more information.



WARNING! Only chargers with Neutrik NC3MX plugs should be connected to the off-board charger/programming socket. See your authorised Pride Dealer for more information.

2-Pin Battery Connector

The controller connector connects the VSI to the power chair's batteries.

Motor Connectors

The left and right motor connectors connect the VSI controller to the power chair's motors and motor brakes.



WARNING! Failure to properly align the connectors can result in damage to the controller, the charger and the connectors.

VIII. OPERATION

Thermal Rollback

The VSI controller is equipped with a thermal rollback circuit. This circuit monitors the temperature of the controller, which roughly translates to motor temperature. In the event that the VSI controller becomes excessively hot (above 60°C/140° F), motor current (amperage) is reduced. For every degree above 60°C (140° F), the motor current limit is reduced by .55 amps until the VSI controller reaches 70°C (158° F), at which time the current output is reduced to zero. This reduces your power chair's "power," which could also reduce your power chair's speed, and allows the electrical components and motors to cool down. When the temperature returns to a safe level, your power chair resumes its normal operation.

VSI Error Codes

The VSI controller is designed with the user's safety as the prime consideration. It incorporates many sophisticated self-test features which search for potential problems at a rate of 100 times per second. If the VSI detects a problem either in its own circuits or in the power chair's electrical system, it may decide to stop the power chair, depending on the severity of the problem. The VSI is designed to maximise the user's safety under all normal conditions. The table below identifies the individual error codes. Error codes are displayed as a rapid flashing of the battery condition meter lights. If you get one of these error codes, contact your authorised Pride Dealer.

FLASHING LIGHTS	DIAGNOSIS AND SOLUTION
1	The batteries need charging or there is a bad connection to the batteries. Check the connections to the batteries. If the connections are good, try charging the batteries.
2	The left motor has a bad connection. Check the left motor connection.
3	The left motor has a short circuit to a battery connection. Contact your authorised Pride Dealer.
4	The right motor has a bad connection. Check the right motor connection.
5	The right motor has a short circuit to a battery connection. Contact your authorised Pride Dealer.
6	The power chair is being inhibited by the battery charger. Unplug the battery charger.
7	A joystick fault is indicated. Make sure that the joystick is in the neutral (centre) position before turning on the controller.
8	A controller system fault is indicated. Make sure that all connections are secure.
9	The parking brakes have a bad connection. Check the parking brake and motor connections. Make sure the controller connections are secure.
10	An excessive voltage has been applied to the controller. This is usually caused by a poor battery connection. Check the battery connections.

VIII. CARE AND MAINTENANCE

CARE AND MAINTENANCE

Your Pride LX is a sophisticated power chair. Like any motorized vehicle, it requires routine maintenance checks. You can perform some of these checks, but others require assistance from your authorised Pride Dealer. Preventive maintenance is very important. If you follow the maintenance checks in this section as scheduled, you can help ensure that your power chair gives you years of trouble-free operation. If you have any doubt as to your power chair's care or operation, contact your authorised Pride Dealer.



WARNING! Prevent injury. Do not service the power chair when the seat is occupied.

Your power chair, like most electrical equipment, is susceptible to damage from the elements. Avoid damp areas of any kind.



WARNING! Direct exposure to water or dampness could cause the power chair to malfunction electronically and mechanically. Water can cause electrical components to corrode and the chair's frame to rust.

Should your power chair come in contact with water:

1. Dry your power chair as thoroughly as possible with a towel.
2. Allow your power chair to sit in a warm, dry place for 12 hours to allow unseen water to evaporate.
3. Check the joystick operation and the brakes before using your power chair again.
4. If any inconsistencies are found, take your power chair to your authorised Pride Dealer.

Temperature

- Some of the parts of your power chair are susceptible to extreme changes in temperature. Always keep your power chair between the temperatures of -8°C (18°F) and 50°C (122°F).
- In extremely cold temperatures the batteries may freeze. The specific temperature at which they freeze depends on a number of factors, such as battery charge, usage and composition of the batteries (e.g., AGM or Gel-Cell).
- Temperatures above 50°C (122°F) may cause your power chair to operate at a reduced speed. This reduced speed is a safety feature built into the controller that helps prevent damage to the motor and other electrical components. See VII. "Operation."

General Guidelines

- Avoid knocking or bumping the controller, especially the joystick.
- Avoid prolonged exposure of your power chair to extreme conditions, such as heat, cold or moisture.
- Keep the controller system clean.
- Check all connectors to ensure that they are all tight and secured properly.
- Make sure the drive tyres are inflated to **2.4 bar (35 psi)** if equipped with pneumatic tyres.



WARNING! Overinflating tyres can cause them to explode and can result in personal injury.

WARNING! Do not use a high pressure hose to inflate your tyres.

- Use a rubber conditioner on the tyre sidewalls to help preserve them.



WARNING! Never use a rubber conditioner on the tread area of the tyres; doing so may make the tyres slippery and cause your power chair to skid.

VIII. CARE AND MAINTENANCE

- Check all electrical connections. Make sure they are tight and are not corroded. Batteries must sit flat within the battery boxes. Refer to the battery wiring label for the correct wiring layout.
- The body shroud has been sprayed with a clear sealant coating. You can apply a light coat of car wax to help it retain its high-gloss appearance.
- All wheel bearings are prelubricated and sealed. They require no subsequent lubrication.

Daily Checks

- With the controller system turned off, check the joystick. Make sure it is not bent or damaged and that it returns to the neutral position when you release it. Check the rubber boot around the base of the joystick for damage. Visually inspect the boot. Do not handle or try to repair it. See your authorised Pride Dealer if there is a problem.
- Visually inspect the controller cable. Make sure that it is not frayed, cut or has any wires exposed. See your authorised Pride Dealer if there is a problem.
- Check for flat spots on solid tyres. Flat spots could adversely affect stability.

Weekly Checks

- Disconnect and inspect the controller from the power base. Look for corrosion. Contact your authorised Pride Dealer if necessary.
- Ensure that all parts of the controller system are securely fastened to your power chair. Do not overtighten any screws.
- Check for proper tyre inflation. There should be **2.4 bar (35 psi)** in each tyre. If a tyre does not hold air, see an authorised Pride Dealer for replacement of the tube.
- Calibrate the joystick if a noticeable difference in performance is detected or if the joystick does not operate properly. To calibrate the joystick, power off the unit, place the joystick in the neutral position and power the unit back on. If a problem still exists with your joystick's performance, contact your authorised Pride Dealer.
- Check the brakes. This test should be carried out on a level surface with at least 1 metre (3 feet) of clearance around your power chair.

To check the brakes:

1. Turn on the unit and turn down the speed level of your power chair.
2. After one second, check the battery condition meter. Make sure that it remains on.
3. Slowly push the joystick forward until you hear the electric brakes click. Immediately release the joystick. You must be able to hear each electrical brake operating within a few seconds of joystick movement. Repeat this test three times, pushing the joystick rearwards, then left and then right.

Monthly Checks

- Check for drive tyre wear. See your authorised Pride Dealer for repair.
- Check the castor wheels for wear. Replace them as necessary.
- Check the castor forks for damage or fluttering which indicates that they may need to be adjusted or have the bearings replaced. See your authorised Pride Dealer for repair.
- Keep your power chair clean and free of foreign material, such as mud, dirt, hair, food, drink, etc.

Yearly Checks

Take your power chair to your authorised Pride Dealer for yearly maintenance. This helps ensure that your power chair is functioning properly and helps prevent future complications.

VIII. CARE AND MAINTENANCE

Storage

Your power chair should be stored in a dry place, free from temperature extremes. When storing, disconnect the batteries from the power chair. See VI. “Batteries and Charging.”



WARNING! If you fail to store the unit properly, the frame can rust and the electronics can be damaged.

Cleaning and Disinfection

- Use a damp cloth and mild, non-abrasive cleanser to clean the plastic and metal parts of your power chair. Avoid using products that may scratch the surface of your power chair.
- If necessary, clean your product with an approved disinfectant. Make sure the disinfectant is safe for use on your product before application.

WARNING! Prevent personal injury and product damage! Follow all safety instructions for the proper use of the disinfectant before applying it to your product.



WARNING! Never hose off your power chair or place it in direct contact with water. Your power chair can be easily wiped clean with a damp cloth.

WARNING! Never use any chemicals to clean a vinyl seat, as they may cause the seat to become slippery or dry out and crack. Use soapy water and dry the seat thoroughly.

Disposal of Your Power Chair

Your power chair must be disposed of according to applicable local and national statutory regulations. Contact your local waste disposal agency or authorised Pride Dealer for information on proper disposal of power chair packaging, metal frame components, plastic components, electronics and batteries.

Wheel Replacement

Your power chair wheels are equipped with solid tyre inserts. In order to replace the wheels, you must replace the entire wheel assembly. If your power chair is equipped with optional pneumatic tyres and you have a flat tyre, you can replace the tube. Replacement tyres, tubes and wheel assemblies are readily available through your authorised Pride Dealer.



WARNING! To avoid possible injury, be sure that the unit's power is turned off and the power chair is not in freewheel mode before performing this procedure.

WARNING! Completely deflate the tyre before attempting repair.

Follow these easy steps for quick and safe wheel replacement:

1. Turn off the power to the controller.
2. Make sure that the power chair is in drive mode.
3. Raise and support the power chair so that the wheel is at least 2.5 cm (1 in.) off of the ground.
4. If you are changing a pneumatic tyre, completely deflate it before removing the wheel.
5. Pry off the hub cap.
6. Remove the drive wheel nut and washers from wheel axle. See figure 34.
7. Pull the wheel assembly off of the axle.
8. Separate the tyre and tube from the rim and replace with a new tube for pneumatic tyres. See figure 35.
9. Slide the wheel assembly onto the shaft. Make sure the axle key is in the axle slot.
10. Reinstall the drive wheel nut and washers onto the axle and tighten.

VIII. CARE AND MAINTENANCE

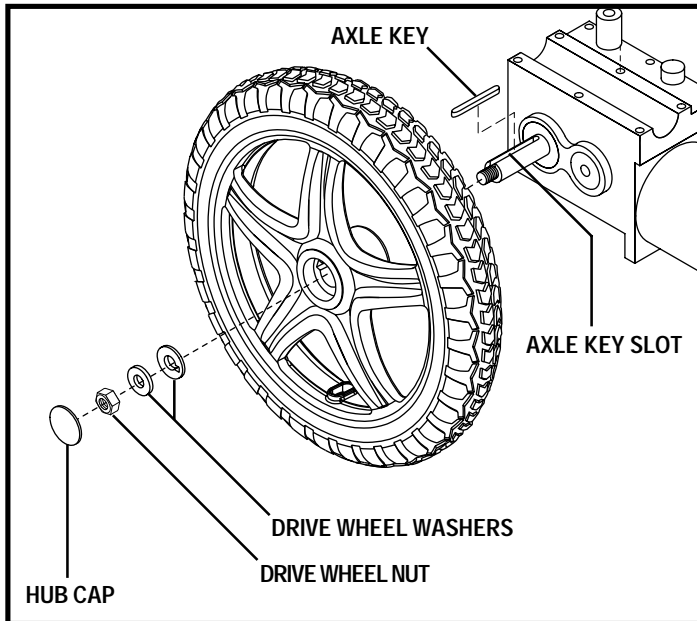

Figure 34. Drive Wheel Replacement

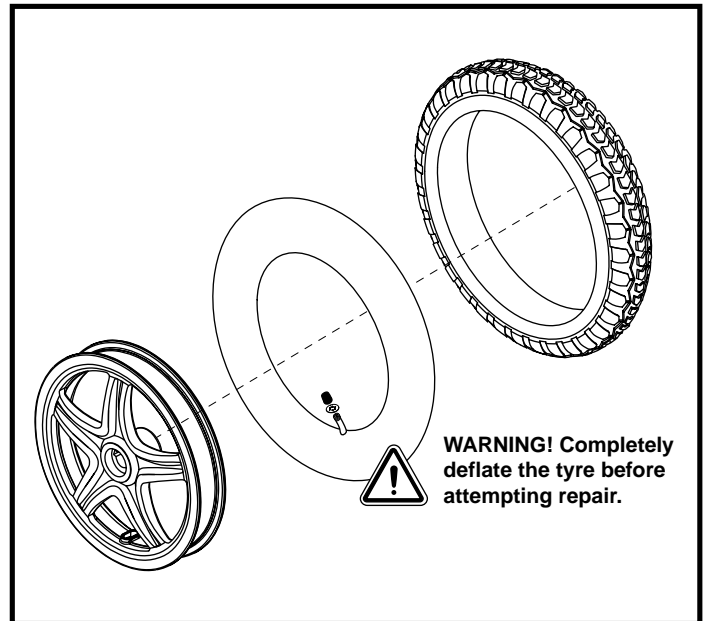

Figure 35. Drive Wheel Disassembly (Pneumatic)

11. Reinstall the hub cap.
12. Inflate pneumatic tyres to **2.4 bar (35 psi)**.

Battery Replacement

WARNING! Prevent injury. Do not replace batteries when seat is occupied.

WARNING! Battery posts, terminals and related accessories contain lead and lead compounds. Wear goggles and gloves when handling batteries and wash hands after handling.



WARNING! Power chair batteries are heavy. See specifications table. If you are unable to lift that much weight, be sure to get help. Lifting beyond your capacity can result in personal injury.

WARNING! Prevent injury and/or equipment damage! Do not mix or match new and old batteries. If you encounter a situation where one battery needs to be replaced, then replace both batteries. Refer to specifications table in this manual and the manual supplied with the battery charger for recommended type and capacities.

To replace the battery:

1. Disconnect the rear battery battery box from the front battery box. See figure 36.
2. Disconnect the rear battery box hold down strap.
3. Lift the rear battery box up and off of the frame.
4. Disconnect the front battery box from the controller. See figure 6.
5. Unstrap the front battery box and lift it up and off of the frame.
6. Move the battery box carrying straps aside.
7. Lift the battery box lid off of each battery box.
8. Disconnect the battery cables from the batteries.
9. Remove the old batteries.
10. Insert the new batteries.
11. Refer to the battery wiring label located on the rear battery box. See figure 37.

VIII. CARE AND MAINTENANCE

12. Connect the red cable to the positive (+) terminal on each battery. See figure 38.
13. Connect the white cable to the negative (-) terminal on each battery. See figure 38.



WARNING! Make sure you tighten the fasteners so that the connections are secure.

14. Place the lid back onto each battery box.
15. Move the battery carrying straps back over the top of each battery box.
16. Place each battery box back onto the frame and connect the battery box straps.
17. Reconnect the battery box connectors.

When to See Your Authorised Pride Dealer for Service

The following symptoms could indicate a serious problem with your power chair. If necessary, contact your authorised Pride Dealer. When calling, have the model number, serial number, nature of the problem and the trouble code if available.

- Motor noise
- Frayed harnesses
- Cracked or broken connectors
- Uneven wear on any of the tyres
- Jerky motion
- Pulling to one side
- Bent or broken wheel assemblies
- Does not power up
- Powers up, but does not move

Corrective Maintenance

If the battery condition meter does not light up when you turn on the power:

- Check the harness connections. Make sure they are tight.
- Check the circuit breakers. Reset it if necessary.
- Check the battery connections.

If the above conditions prove normal, you can load test the batteries with a battery load tester. These testers are available at automotive parts stores. Disconnect both batteries before load testing and follow the directions that come with the load tester. If either one of the batteries fails the load test, replace both of them. If your power chair still does not power up, contact your authorised Pride Dealer.

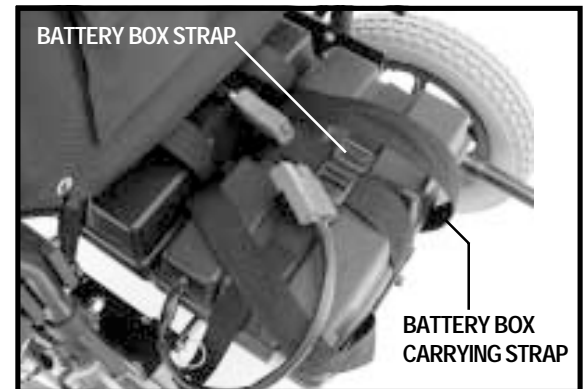

Figure 36. Rear Battery Box Connector



Figure 37. Battery Wiring Label

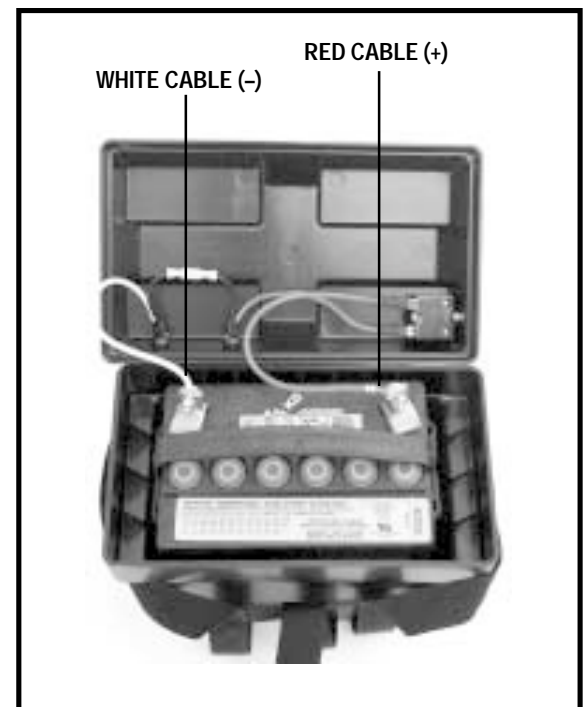

Figure 38. Battery Installation

I X . W A R R A N T Y

LIFETIME WARRANTY

Structural frame components, including: platform, fork, seat post and frame welds.

TWO-YEAR LIMITED WARRANTY

Drivetrain, including: motor and brake.

EIGHTEEN-MONTHS LIMITED WARRANTY

Controllers: Any attempt to open or dismantle these parts will lead to this warranty being void.

ONE-YEAR LIMITED WARRANTY

All electrical parts, including battery chargers, are covered for one year under warranty. Any attempt to open or dismantle these parts will lead to this warranty being void.

BATTERIES

Batteries are covered by a twelve-month warranty from the original manufacturer.

NOT COVERED UNDER WARRANTY

The following parts are classed as wear items, which may, under normal wear and tear, require replacing. These items are **not** therefore covered under warranty: tyres, positioning belts, bulbs, upholstery, plastic shrouds, motor brushes, fuses and batteries. Warranty will also be refused if damage is deemed to have been caused through misuse or accident for which Pride Mobility Products Ltd. cannot be deemed responsible.

NOTE: Pride Mobility Products Ltd. provides parts only under warranty. Your authorised Pride Dealer is responsible for labour and service. Please contact your authorised Pride Dealer for information about these services and for any applicable charges.

NOTES

NOTES

Pride LX



Quality Control Checklist

Thank you for making the Pride LX your choice in power chairs. The following checkmarks indicate that we have thoroughly inspected and test driven your power chair.



Inclusion of all Parts

Joystick Serial Number

Controller Serial Number

Left Motor Serial Number

Right Motor Serial Number

Fit and Finish

Performance

Pride keeps a more detailed report on file at the factory.

Date Inspected

Inspector

* I NFMANU1691 *

Product Serial Number